

H. P. CASE.  
Chuck.

No. 209,459.

Patented Oct. 29, 1878.

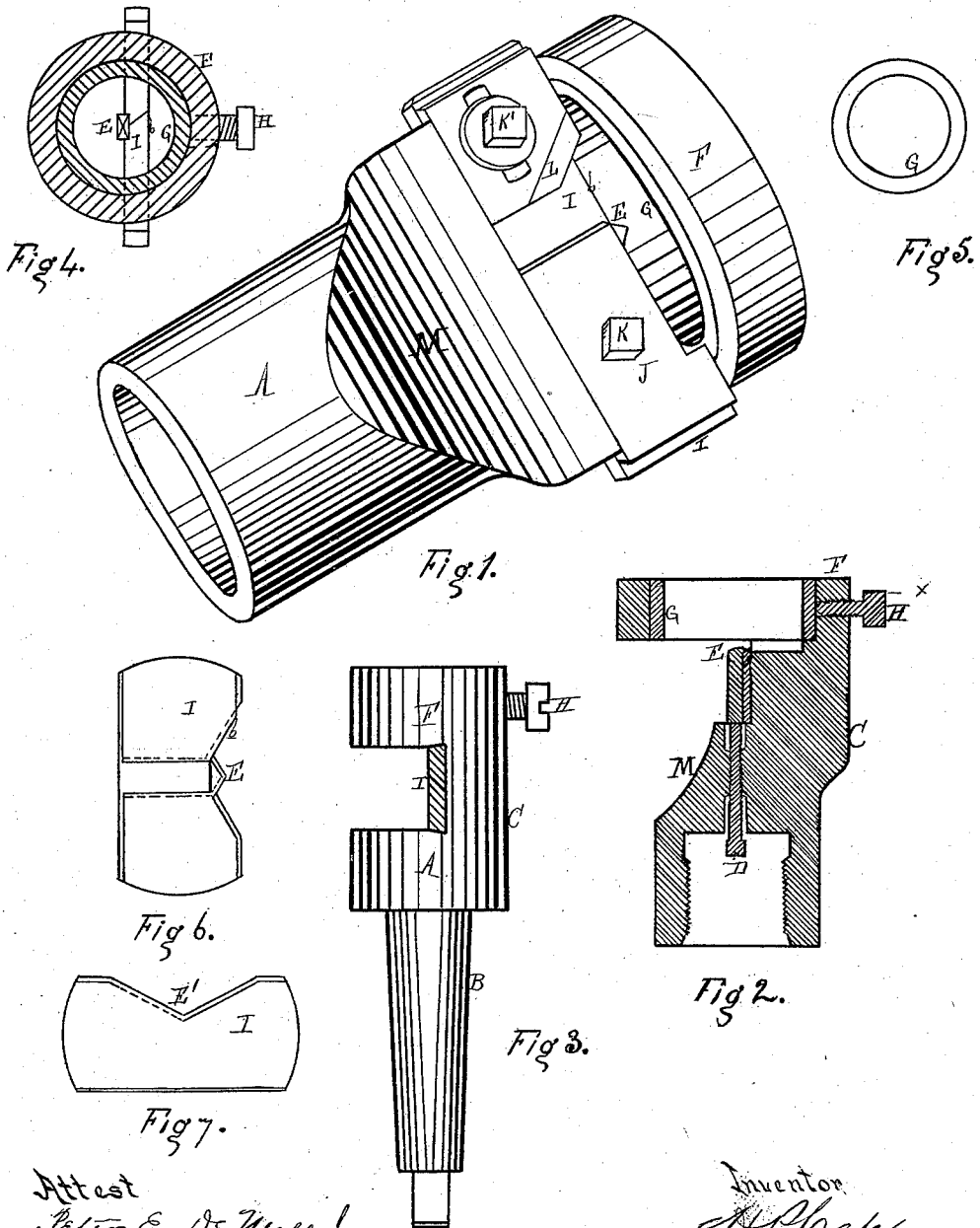

Attest  
Peter C. De Muel jr.  
Charles J. Hunt

Inventor  
H. P. Case  
By Atty.  
Thos. S. Sprague

# UNITED STATES PATENT OFFICE.

HIRAM P. CASE, OF DETROIT, MICHIGAN.

## IMPROVEMENT IN CHUCKS.

Specification forming part of Letters Patent No. **209,459**, dated October 29, 1878; application filed April 13, 1878.

*To all whom it may concern:*

Be it known that I, HIRAM P. CASE, of Detroit, in the county of Wayne and State of Michigan, have invented an Improvement in Chucks, of which the following is a specification:

The nature of my invention relates to new and useful improvements in that class of chucks which are employed, in combination with a lathe or other device, for holding and centering shafting or other articles; and the invention consists in the peculiar construction and arrangement of the various parts, and their combination with a cutter, by means of which the end of the shaft is finished, as more fully hereinafter described.

Figure 1 is a perspective of my device. Fig. 2 is a vertical central section. Fig. 3 is a side elevation of a modification of Fig. 1. Fig. 4 is a cross-section on the line  $xx$  in Fig. 2. Fig. 5 is a plan view of the loose centering-ring. Figs. 6 and 7 are modifications of the centering-point.

In the drawings, A represents a cylinder, which forms the base of my tool, and by its means the tool is secured to the mandrel B or shank of a lathe or drilling-machine. This cylindrical portion is short, and terminates in a solid portion, C, which is centrally tapped, as shown in Fig. 2, to receive the set-screw D, the end of which rests against the bottom of the centering-bit E, and by means of said set-screw the bit is made to project more or less, as may be desired. The outer end of the tool terminates in a guide-ring, F, within which may be inserted any loose centering-ring, G, of any required thickness, and this ring is held in place by the set-screw H. This bit E is inserted in the plate I in the front edge thereof, as shown in Fig. 4, and the clamp-plate J holds said bit in place. These plates are secured in place by the bolts K K'; or the bit may be held in place by dovetailing it into the edge of the plate I, as shown in Fig. 6, which is preferable in small tools. L is a cutter, of the form shown, which is adjustably attached to the plate I by means of a longitudinal slot,  $a$ ,

and the bolt K'. M is a cut-away portion from the solid part C of the tool, forming a throat which gives easy access to the hereinbefore-named working parts for the purpose of adjusting them. In Fig. 7 another form of the plate I is shown to be employed when it is desired to round off or taper the end of a bolt accurately. To this end the plate is provided with cutting-edges E', and the center-bit is not required. The plate I, employed with the centering-bit, is provided with a cutting-edge at  $b$ , to finish the end of the shaft or bolt, while the cutter L cuts off and finishes the edge.

In practice the operation of this tool is as follows: We will suppose the bore of the guiding-ring F to be two inches in diameter, and it is desired to work a shaft or bolt of one and a half inch in diameter. A reducing-ring, G, is inserted within F, so as to reduce the diameter nearly to the size of the bolt to be operated upon, and secured by the set-screw H. The bolt is then inserted and the lathe started. The cutter L is first brought into contact with the end edge of the bolt, and commences cutting that off, and, feeding up, the centering-bit cuts its way into the exact center of the bolt, and when thus centered the cutting-edge  $b$  of the plate I finishes the end of the bolt flat, as shown in Fig. 1, or slightly conical or rounded, as shown in Fig. 6. The cutter L is adjustable, as described, to enable the operator to adjust it to bolts of different sizes.

What I claim as my invention, and desire to secure by Letters Patent, is—

In a tool for finishing the ends of shafts or bolts, the combination, with the body A, of the guide-ring F on the end of body, provided with a set-screw, H, to hold a centering-ring, the plate I in the throat of the body, carrying the centering-bit E, which rests on an adjusting-screw, D, the clamping-plates J, and cutters L, substantially as described and shown.

HIRAM P. CASE.

Witnesses:

H. S. SPRAGUE,  
CHARLES J. HUNT.